

### Reliability You Can Trust

At Resource Materials Corporation, trust and integrity are important cornerstones of our business. We take expert care in the manufacturing process to ensure all our vinyl siding products perform to the highest standards. And we back this pledge with a Limited Lifetime Transferable Warranty. When it comes to home improvement, experience makes all the difference. RMC is the only name you need to know for a lifetime of home beauty.



YOUR AUTHORIZED RMC DEALER



2450 Enterprise St. • Fremont, OH 43420 • 800 846-9599 • [www.rmcsiding.com](http://www.rmcsiding.com)



Kynar® and Solarkote® are registered trademarks of Arkema, Inc. The Carrington Collection Vinyl Siding passes or exceeds all industry standards per ASTM D3679. Made in the U.S.A. by America's dedicated workforce. Specifications subject to change without notice.

30317 5/10 Printed in U.S.A. © Copyright 2010



*The Carrington*<sup>™</sup>  
COLLECTION

# The Carrington Premium Vinyl Siding Collection...

## Create a home of distinction

The Carrington Collection will transform your home with distinctive elegance, beautiful colors, and the ultimate in protection. Whether remodeling or new construction, the Carrington Collection is the first choice for classic good looks in the American siding tradition.

The Carrington Collection features extra rigidity to go on straight and retain its pristine appearance for the lifetime of your home. Three color palettes give you 20 stylish color choices to reveal the personality of you and your home:

- **Woodland Series™** - four naturally variegated colors of nature
- **Legacy Series™** - five sophisticated darker tones
- **Traditional Series™** - eleven time-honored colors

The Carrington Collection's use of high-performance cap stock produces fade-resistant colors and a lifetime of durability. Exclusive double-staggered nail hems and deep bottom laps withstand gale force winds to protect your beautiful investment.

The Carrington Collection is backed by a Limited Lifetime Transferable Warranty. Create a home of distinction with the Carrington Collection.



### Carrington At A Glance:

- Extra-thick design (.048 inches) is exceptionally rigid and straight
- Superb durability and impact resistance
- Double-staggered **Tuff-Hem™** nail hem and 3/4-inch bottom **Tuff-Lock™** lap combine to withstand gale force winds
- Legacy and Traditional Series feature premium **Armor Coat UVA™** and **Solarkote®PB** high-performance polymers to resist fading. The Woodland Series features a **Kynar® PVDF** film finish for outstanding durability and advanced color protection.
- Three panel profiles: D4 - Double 4, DL5 - Dutch Lap 5, D6 - Double 6
- Limited Lifetime Transferable Warranty

#### Double-Staggered Tuff-Hem™ Nail Hem

Carrington Siding provides twice the nailing surface of standard siding. Every sheet has two rows of slots in staggered configuration that not only enhances the stability of the siding to withstand sagging or twisting, but also greatly improves attachment strength allowing it to withstand gale force winds.

Carrington's double staggered nail hem vs. typical single nail hem.

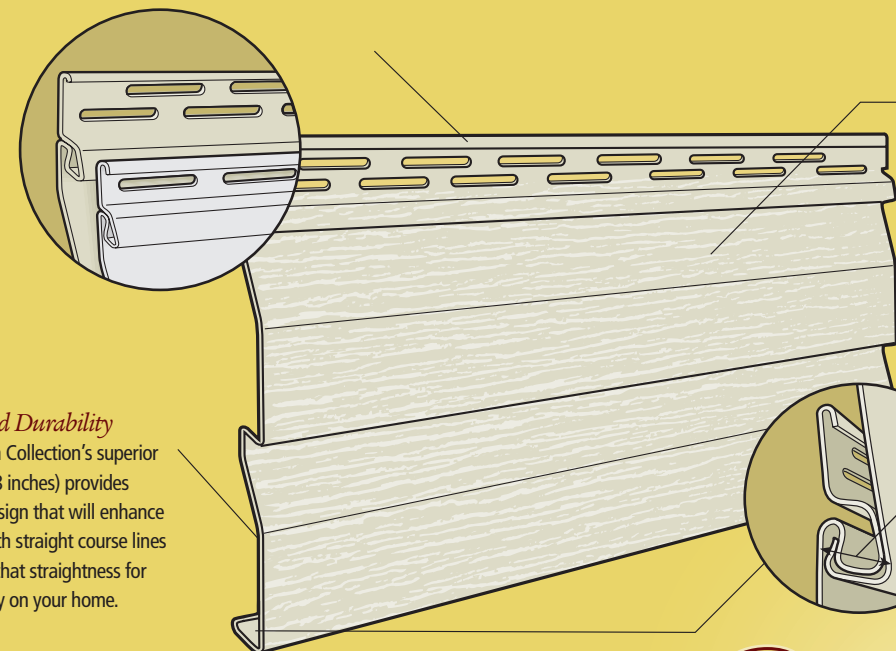

#### Strength and Durability

The Carrington Collection's superior thickness (.048 inches) provides strength by design that will enhance installation with straight course lines and maintain that straightness for years of beauty on your home.

#### Enhanced Impact Resistance

Carrington Premium Vinyl Siding exceeds industry standards for impact resistance by 25 percent to virtually eliminate dents or dings in siding. (Test: ASTM D3679).

#### Molded with Armor Coat UVA™ and Solarkote®PB High Performance Polymers

An exclusive blend of the best raw materials, UV stabilizers and performance modifiers give the Carrington Collection Premium Vinyl Siding superb color retention and weatherability. Even the newest, dark colors will resist fading so that your home will look great for a lifetime. The Woodland Series features a **Kynar®PVDF** film finish for outstanding durability and advanced color protection.

#### Tuff-Lock™ Bottom Lap

Carrington's Tuff-Lock™ Bottom Lap measures 3/4" across – 20 percent larger than standard siding for the ultimate in locking integrity. Carrington's innovative design matches the contour of the top curl for superior attachment.

## The Carrington™ COLLECTION

### Carrington Color Palettes:

